

Product Information

Periphery module

PM AI802

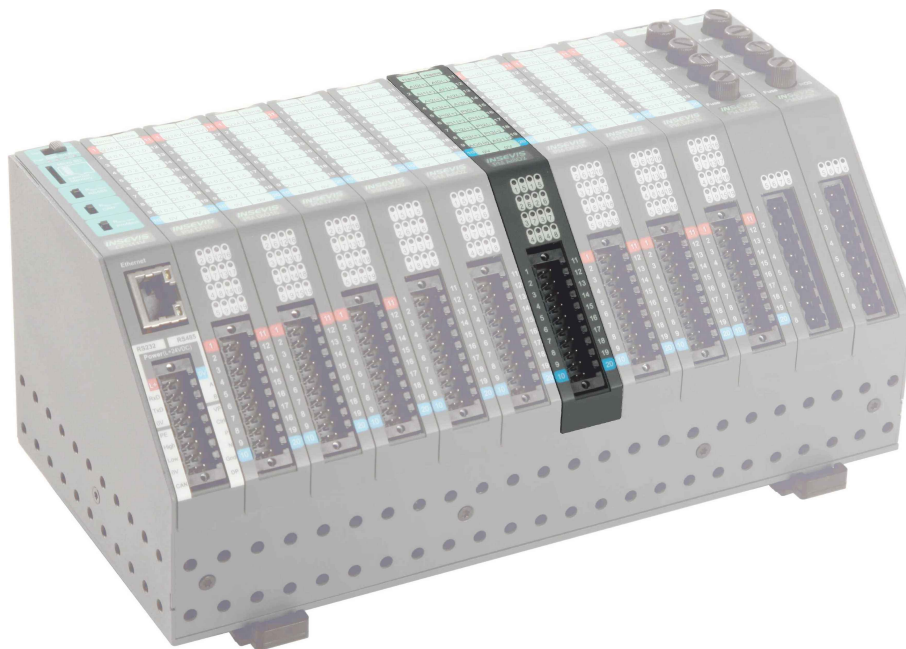

(valid from 06/2012)

Changes to older versions of this document

Changed in Rev. 5: Temperature range PT100, connectors, new design line
Changed in Rev. 6: information for disposal of old equipment

Description

- compact periphery module for
- **8 analog inputs**
4x 4mA...20mA
4x PT100
 - 2 analog outputs**
2x 4mA...20mA
 - Resolution 12 Bit
 - green diagnostic LED for each input
 - red diagnostic LED for short cut detection or temperature below - 50°C)
 - insertion stripe with description field for every signal
 - cage-clamp connector with bolt flanges on side

INSEVIS-benefit:

This module has an internal supply for the 2-wire encoders (4-20mA). So it is not necessary to care for external supply!

If you use these pins 1-4, do not apply external encoder supply!

for 2-wire encoders

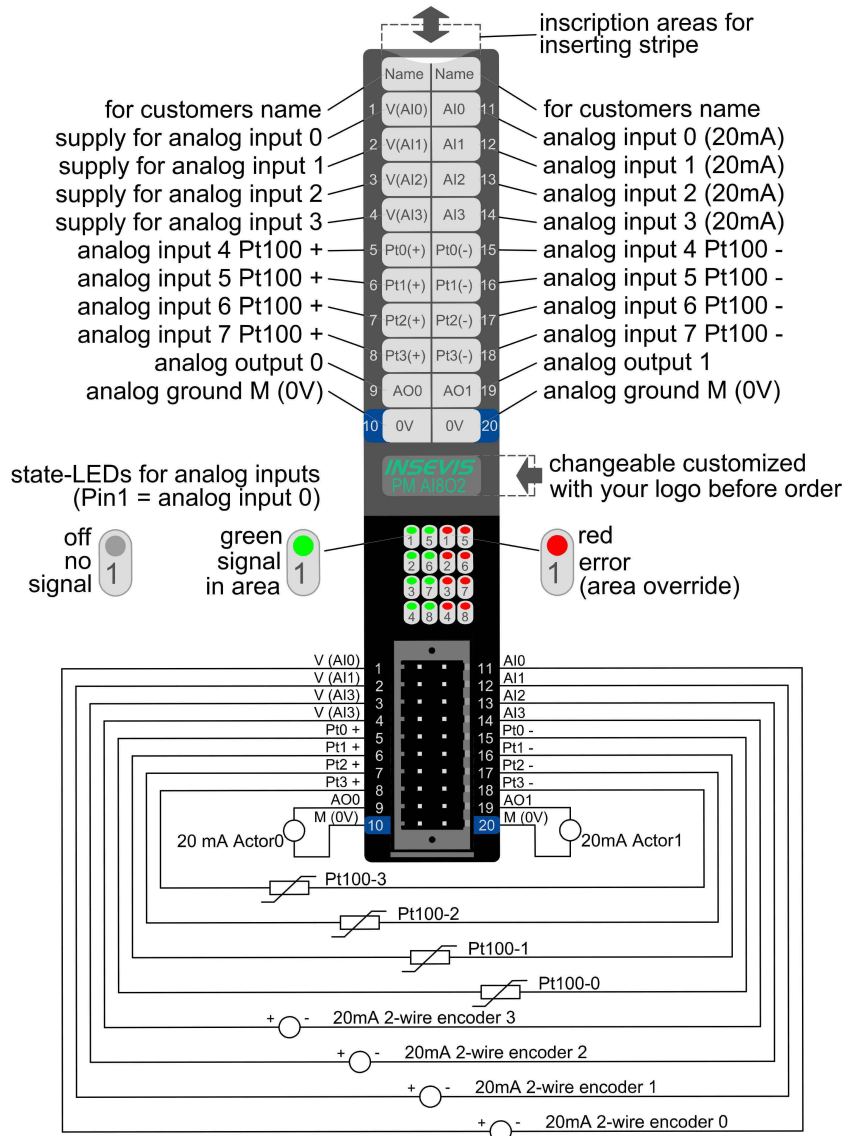

Figure above: Description and wiring of all connections of periphery module AI8O2 for 2--wire encoders

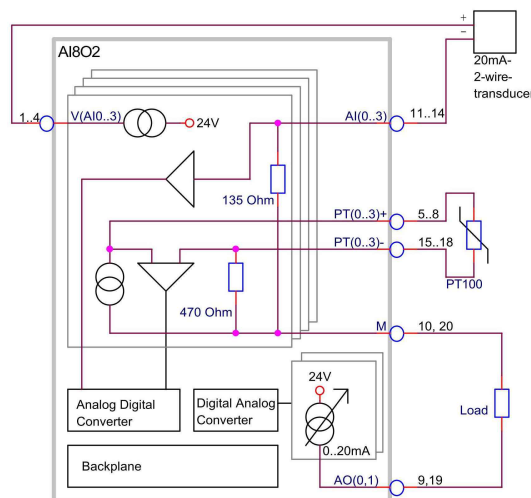

Figure above: Block diagram PM AI8O2 for 2-wire encoders

Input

Start address:

End address:

Output

Start address:

End address:

General

Integration time [ms]

Figure above: configuration block of the start-/ end addresses of AI8O2-i/o's (in words) in the ConfigStage

Description

compact periphery module for

- 8 analog inputs**
4x 4mA...20mA
4x PT100
- 2 analog outputs**
2x 4mA...20mA
- Resolution 12 Bit
- green diagnostic LED for each input
- red diagnostic LED for each input for error (short cut detection or temperature below - 50°C)
- insertion stripe with description field for every signal
- cage-clamp connector with bolt flanges on side

Attention!

This module has an internal supply for the 2-wire encoders (4-20mA).

Do not connect pins 1-4 when using 3/4-wire encoders!

for 3- / 4-wire encoders

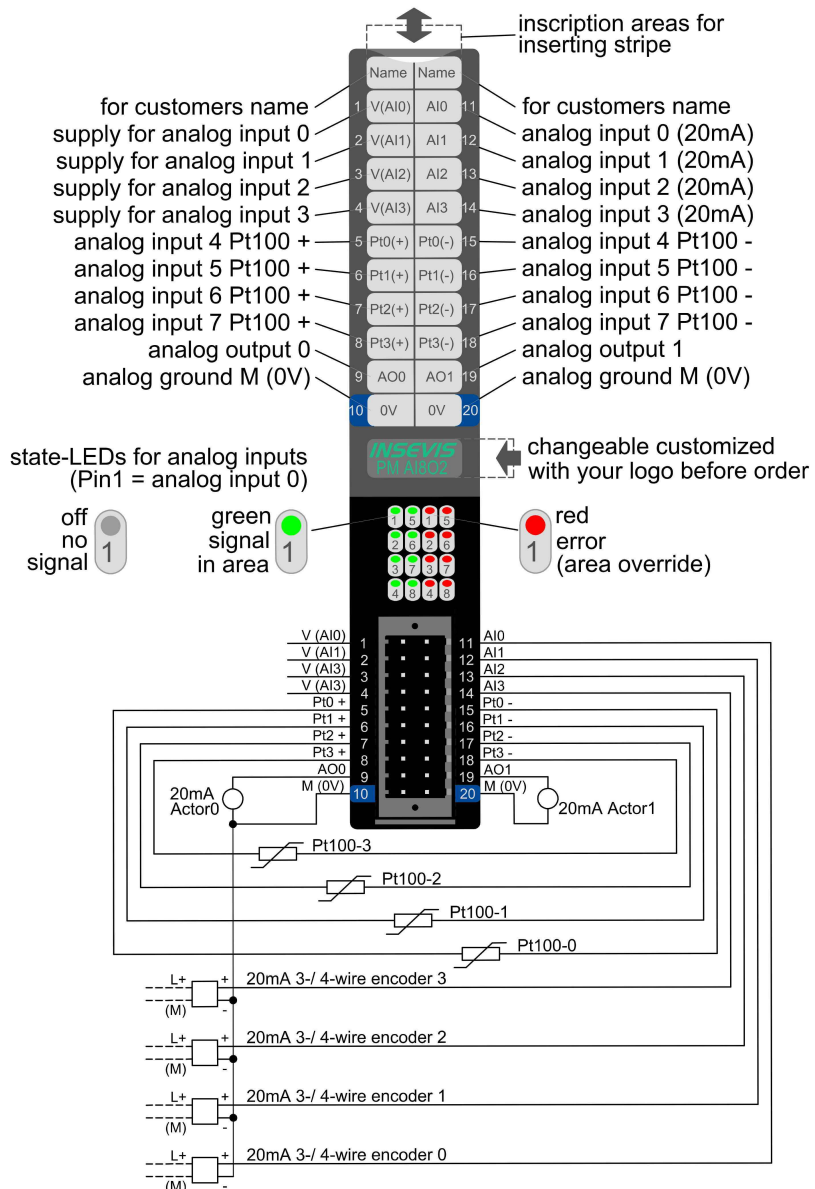

Figure above: Description and wiring of all connections of periphery module AI802 for 3-/ 4-wire encoders

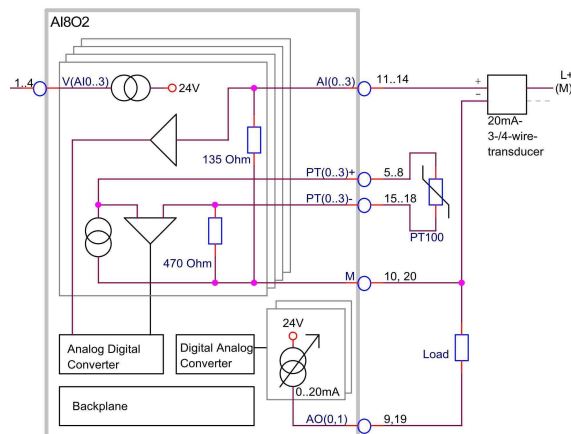

Figure above: Block diagram PM AI802 for 3-/ 4-wire encoders

Input	
Start address:	128
End address:	143
Output	
Start address:	128
End address:	131
General	
Integration time [ms]	0

Figure above: configuration block of the start-/ end addresses of AI802-i/o's (in words) in the ConfigStage

Technical data			
Operating temperature range Storage temperature range Dimensions W x H x D (mm) Weight	-20°C ... +60°C (without condens.) -30°C ... +80°C 20 x 108 x 70 mm ca. 150 g	Load voltage L+ Current consumption Power dissipation	24V DC (10V ... 30V DC, connected by device supply) 150 mA (max.) 2 W (max.)
Connection technology	connector with cage clamp technology for cross section up to max. 1,5mm ²	Wire length unshielded (max.) shielded (max.)	30 m 100 m
Analog inputs	8	valid voltage between inputs and A-GND (max.)	0 V ... +24 V DC
Input area (nominal values)	AE 0...3: 4 mA ... 20 mA AE 4...7: PT100 -200°C ... +300°C	Error message during override metering area	adjustable diagnosis- and limit value alert on request
Under- / override areas	0 mA ... < 4mA >20 mA ... 23 mA -243°C ... <-200°C >+300°C ... +450°C	Broken wire detection	by overrun / shortfall of metering area
Diagnostic LEDs	4 green: 4-10mA-signal in valid area 4 green: PT100: -50°C ... 300°C 4 red: override (mA) or short circuit 4 red: PT100-short cut or temperature below ≤ - 50°C no displaying broken wires and open inputs	Access of sensor	unsymmetric against A-GND (single ended) for metering area 4 mA ... 20 mA 2-wire, symmetric for metering area PT100
Input resistance	120 Ω (typ.) metering area 20 mA 500 Ω (typ.) metering area PT100	Value number format	0000 ... 6C00 (hexadecimal) for metering area 4 mA ... 20 mA 0,1°C for metering area PT100
Resolution	12 Bit	Integration time	adjustable 17 ms or 20 ms
Metering principle / conversion principle	successive approximation	Specifity (based on input area)	< 1%
Sampling cycle time (typ)	1 ms	Current limitation	50 mA
Analog outputs	2	Value number format	0000 ... 6C00 (hexadecimal) for metering area 4 mA ... 20 mA
Output area (nominal values)	4 mA ... 20 mA	Short cut protection	ja
Override area	20 mA ... 23 mA	Short cut current (typ.)	32 mA
Resolution	12 Bit	Setting time: response time τ (typ)	5 ms
Load resistance against A-GND	4..20 mA: 500 Ω (max.)	Specifity (based on output area)	< 1%

Ordering data module		
Identification	Order-no.	Packaging unit
Periphery module AI8O2	PM-AI8O2-02	PU: 1 piece
Connector 2x10pin with pin markings and bolt flanges on side	E-CONS20A-00	PU: 1 piece

Qualified personnel

All devices described in this manual may only be used, built up and operated together with this documentation. Installation, initiation and operation of these devices might only be done by instructed personnel with certified skills, who can prove their ability to install and initiate electrical and mechanical devices, systems and current circuits in a generally accepted and admitted standard.

Manuals, sample programs

Additional documentation by manuals is available as well sample applications at the download area of www.insevis.com in English language for free download.

Copyright

This and all other documentation and software, supplied or hosted on INSEVIS web sites to download are copyrighted. Any duplicating of these data in any way without express approval by INSEVIS GmbH is not permitted. All property and copy rights of these documentation and software and every copy of it are reserved to INSEVIS GmbH.

Trade Marks

INSEVIS refers that all trade marks of particular companies used in own documentation are reserved trade marks are property of the particular owners and are subjected to common protection of trade marks.

Disclaimer

All technical details in this documentation were created by INSEVIS with highest diligence. Anyhow mistakes could not be excluded, so no responsibility is taken by INSEVIS for the complete correctness of this information. This documentation will reviewed regularly and necessary corrections will be done in next version. With publication of this data all other versions are no longer valid.

Disposal

Do not throw old appliances in the household waste! In the interest of environmental protection, old appliances must be collected separately from unsorted municipal waste. You can find out more about the proper disposal / return of your old appliance at www.insevis.com/disposal.

■ Attention: The deletion of personal data on the old devices to be disposed of is the responsibility of the end user.

With publication of this information all other versions are no longer valid.